

**LECTURE NOTES ON
REFRIGERATION & AIR-CONDITIONING**

**5TH SEMESTER
MECHANICAL ENGINEERING**

**PREPARED BY:-
Mr. ROHAN
PATTANAYAK
LECTURER
GOVT. POLYTECHNIC, KORAPUT**

Refrigeration and air conditioning notes

Refrigeration is defined as the process of achieving and maintaining a temperature below that of the surroundings. The aim is to cool some product or space to the required temperature.

Air Conditioning refers to the treatment of air and to simultaneously control its temperature, moisture content, cleanliness, odour and circulation, as required by occupants, a process, or products in the space.

Difference between a Refrigerator, Heat Pump, and Heat Engine

A heat engine is a system that converts Thermal energy into Mechanical Energy.

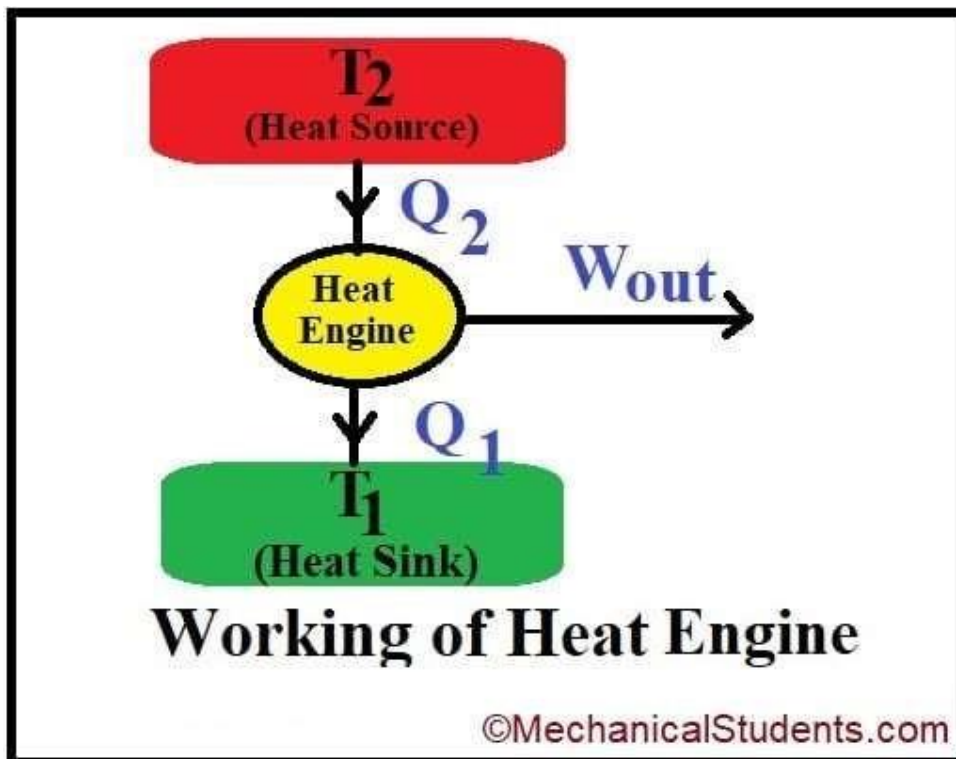

In a heat engine, the heat supplied to the engine is converted into useful work. If Q_2 is the heat supplied to the engine and Q_1 is the heat rejected from the heat engine, then the **network done** by the engine is given by

$$W_e = Q_2 - Q_1$$

So the performance of the engine or Efficiency is given by

Generally, **Efficiency** is calculated as $= W_e/Q$

A refrigerator is a reversed heat engine, where heat is pumped from low temperature (cold body $\rightarrow Q_1$) to high temperature (hot body $\rightarrow Q_2$)

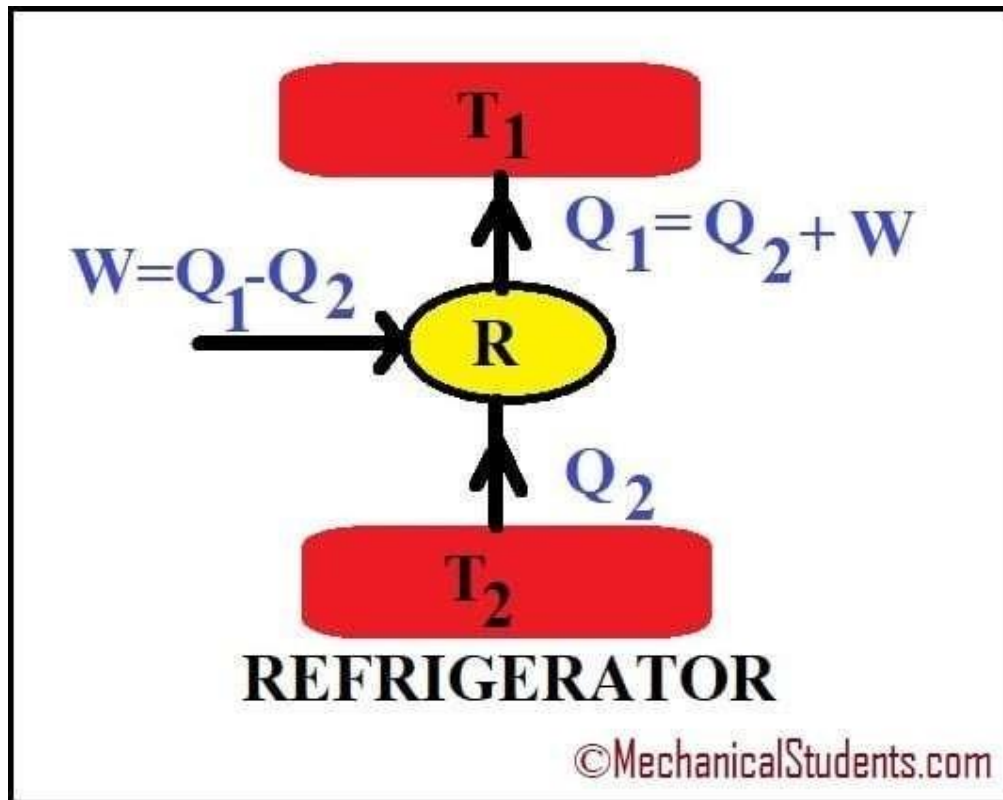

So, Work W_R is required to be done on the system.

$$W_R = Q_2 - Q_1$$

The performance of a refrigerator is the "ratio of the amount of heat taken from the Cold body Q_1 to the amount of work to be done on the system W_R ."

Any refrigerating system is a heat pump, which extracts heat from a cold body and delivers it to a hot body.

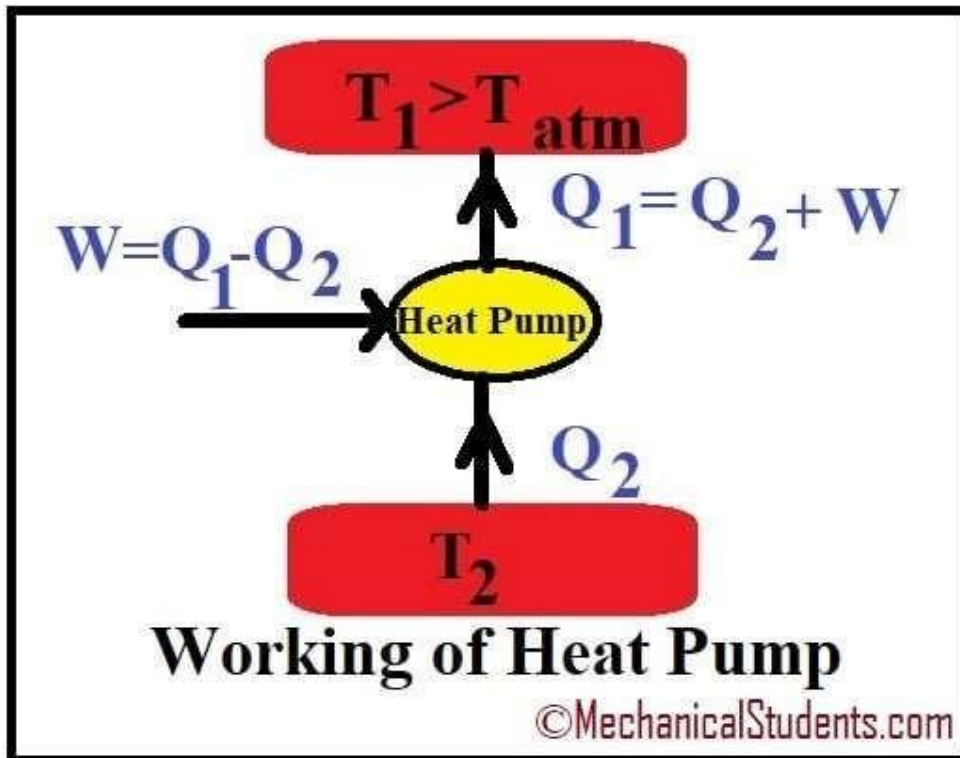

Thus there is no difference in the operation cycle of a refrigerator and a heat pump.

- The main difference between them is in their operating temperatures.
- A refrigerator works between cold body temperature (T_1) and atmospheric temp (T_a) whereas the heat pump operates between hot body temp (T_2) and the atmospheric temperature (T_a).
- A refrigerator used for cooling in summer can be used as a heat pump for heating in the winter season.
- so $W_p = Q_2 - Q_1$

Performance of refrigerator and heat pump

COP(Coefficient of performance)

COP is defined as the relationship between the power (kW) that is drawn out of the heat pump as cooling or heat, and the power (kW) that is supplied to the compressor.

the C.O.P is the reciprocal of efficiency and is given as

$$(C.O.P)_R = Q_1 / W_R = Q_1 / (Q_2 - Q_1) \text{----- for refrigerator}$$

$$(C.O.P)_{hp} = Q_2 / W_R = Q_2 / (Q_2 - Q_1) \text{----- for heat pump}$$

Refrigerator	Heat Pump	Heat Engine
A refrigerator is a reversed heat engine, where heat is pumped from a body at low temperature to a body at high temperature.	Any refrigerating system is a heat pump, which extracts heat from a cold body and delivers it to a hot body.	A heat engine is a system which converts Thermal energy into Mechanical Energy.
The network done by the refrigerator is given by $W_R = Q_2 - Q_1$	The network done by the heat pump is given by $W_p = Q_2 - Q_1$	The network done by the engine is given $W_e = Q_2 - Q_1$
The C.O.P. of Refrigerator is $(C.O.P)_R = \frac{Q_1}{W_R} = \frac{Q_1}{Q_2 - Q_1}$	The C.O.P. of heat pump is $(C.O.P)_{hp} = \frac{Q_2}{W_p} = \frac{Q_2}{Q_2 - Q_1}$	The C.O.P. of heat engine is $(C.O.P)_e = \frac{Q_2 - Q_1}{Q_2}$

Unit of refrigeration

Rating for Refrigeration indicates the rate of removal heat. The unit of refrigeration is expressed in terms of ton of refrigeration (TR). One ton of refrigeration is defined as the amount of refrigeration effect (heat transfer rate) produced during uniform melting of one ton (1000kg) of ice at 0°C to the water at the 0°C in 24 hours.

Calculation for one ton of refrigeration

Latent heat of ice is 335KJ/kg (heat absorbed during melting of one kg ice)

1 Ton of refrigeration, 1TR= 1000*335 in 24 hours

$$= \frac{1000 \times 335}{24 \times 60} \text{ in one minute}$$

$$= 232.6 \text{ kJ/min}$$

Theoretically one Ton of refrigeration taken as 232.6kJ/min, in actual practice, it is taken as 210kJ/min.

1 ton of refrigeration approximately equal to 3.5kW.

Lecture note-2

Sub-Refrigeration and air conditioning

Sem- 5th sem diploma mechanical engg

Open and Closed Type of Refrigeration System – Advantages and Application

Air cycle refrigeration is one of the earliest methods used for cooling. The key features of this method is that, the refrigerant air remain gaseous state throughout the refrigeration cycle. Based on the operation, the air refrigeration system can be classified into

1. Open air refrigeration cycle
2. Closed refrigeration cycle

Open air refrigeration cycle

In an open refrigeration system, the air is directly passed over the space is to be cooled, and allowed to circulate through the cooler. The pressure of open refrigeration cycle is limited to the atmospheric pressure. A simple diagram of the open-air Refrigeration system is given below.

Advantages and application

- It eliminates the need of a heat exchanger.
- It is used in aircraft because it helps to achieve cabin pressurization and air conditioning at once

Disadvantages

One of the disadvantages of this system is that its large size. The air supplied to the refrigeration system is at atmospheric pressure, so the volume of air handled by the system is large. Thus the size of compressor and expander also should be large. Another disadvantage of the open cycle system is that the moisture is regularly carried away by the circulating air, this leads to the formation of frost at the end of the expansion process and clogs the line, and hence a use of dryer is preferable to the open air refrigeration system.

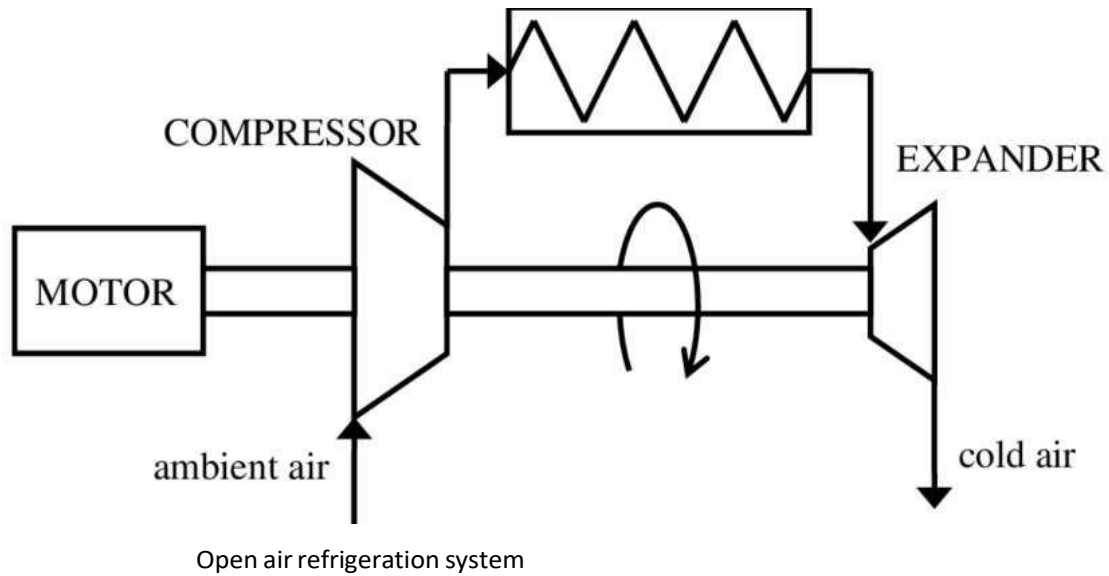

Closed refrigeration system / Dense air refrigeration cycle

In closed or dense air refrigeration cycle, air refrigerant is contained within pipes and component part of the system at all time. The circulated air does not have to direct contact with the space to be cooled. The air is used to cool another fluid (brine), and this fluid is circulated into the space to be cooled. So the disadvantages listed in open air refrigeration can be eliminated. The advantages of closed air refrigeration system are listed below.

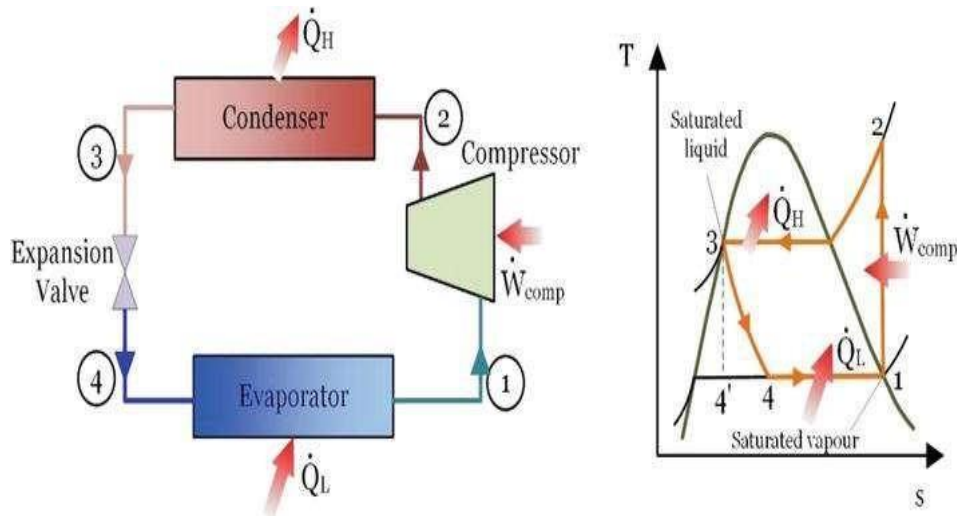

Advantages

- The suction to the compressor may be at high pressure, therefore the volume of air handled by the compressor and expander is low when compared to an open system. Hence the size of compressor and expander is small compared to the open air system.
- The chance of freezing of moisture and choke the valve is eliminated.

- In this system, higher [coefficient of performance](#) can be achieved by reducing operating pressure ratio.

Lecture note

Sub-Refrigeration and air conditioning

Sem- 5th sem diploma mechanical engg.

Air Refrigerator Working On Bell-Coleman Cycle with PV and TS Diagram (Reversed Brayton or Joule Cycle)

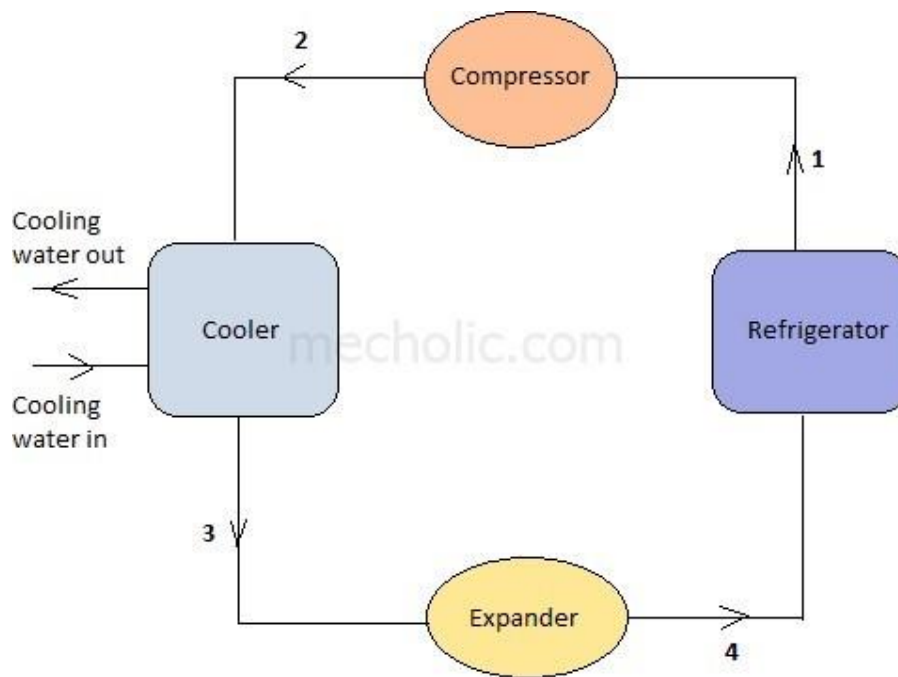
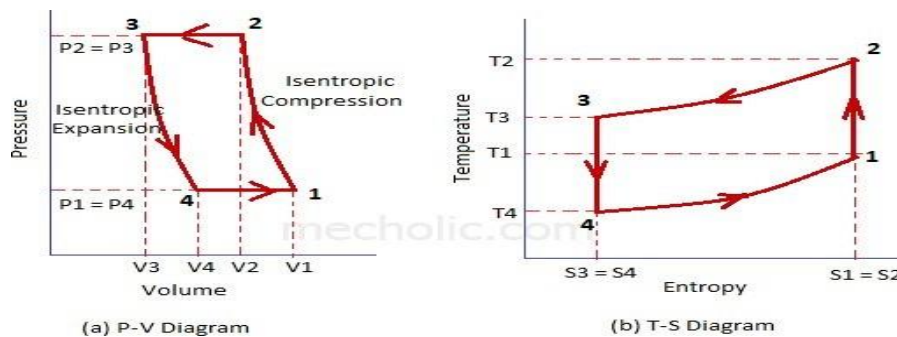

Fig shows a schematic diagram of Bell-Coleman refrigerator (reverse Brayton or joule cycle). This refrigeration system components consists of a **compressor**, cooler, Expander, and refrigerator. In this process, heat absorption and rejection follows at the constant pressure; the compression and expansion of process are isentropic.

Process in Bell-Coleman refrigeration



(a) P-V Diagram

(b) T-S Diagram

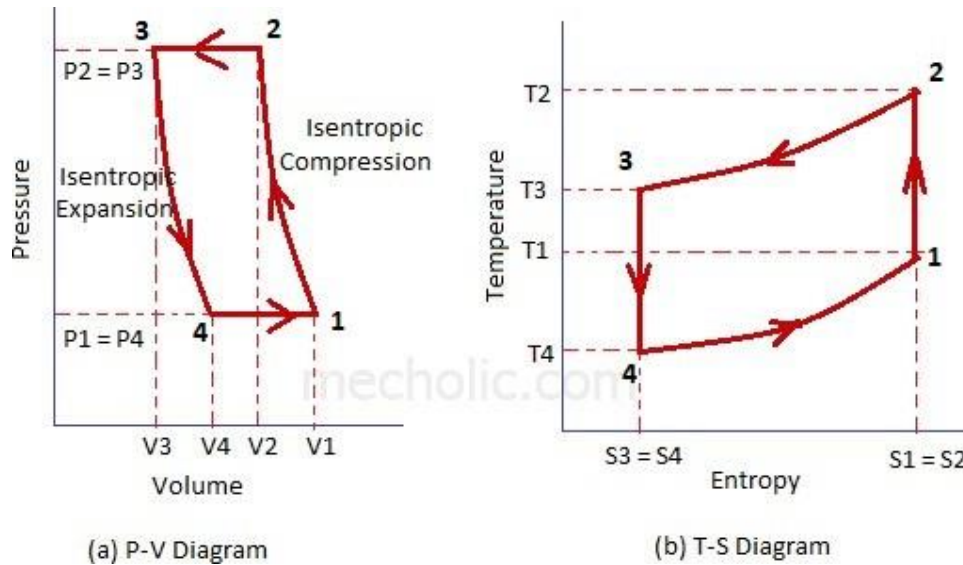

Fig show P-V and T-S diagram of bell coleman refrigerator. Here P_1, V_1, T_1, S_1 represents the pressure, volume, temperature, entropy of air respectively at point 1. And so on. It represents the corresponding condition of air when it passed through the component.

1-2: Isentropic Compression

The Air drawn from refrigerator to air compressor cylinder where it compressed isentropically (constant entropy). No heat transfer by the air. During compression, the volume decreases while the pressure and temperature of air increases.

2-3: Constant pressure cooling process.

The warm compressed air is then passed through cooler, where it cooled down at constant pressure. The heat rejected per kg of air during this process is equal to

$$q_{2-3} = C_p(T_2 - T_3)$$

3-4: isentropic expansion

No heat transfer takes place. The air expands isentropically in expander cylinder. During expansion, the volume increases, Pressure P_3 reduces to P_4 . (P_4 = atmospheric pressure). Temperature also falls during expansion from T_3 - T_4 .

4-1: Constant pressure expansion

Heat transfer from the refrigerator to air. The temperature increases from T_4 to T_1 . Volume increases to V_4 due to heat transfer. Heat absorbed by air per kg during this process is equal to

$$q_{4-1} = C_p(T_1 - T_4)$$

Equation of Coefficient of performance (COP) of Bell Coleman cycle

Heat absorbed during cycle per kg of air $q_{4-1} = C_p(T_1 - T_4)$

Heat rejected during cycle per kg of air $q_{2-3} = C_p(T_2 - T_3)$

Then the work done per kg of air during the cycle is = Heat rejected – Heat absorbed

$$= C_p(T_2 - T_3) - C_p(T_1 - T_4)$$

Coefficient of performance,

$$\begin{aligned} \text{C.O.P.} &= \frac{\text{Heat absorbed}}{\text{Work done}} = \frac{C_p(T_1 - T_4)}{C_p(T_2 - T_3) - C_p(T_1 - T_4)} \\ &= \frac{(T_1 - T_4)}{(T_2 - T_3) - (T_1 - T_4)} \\ \text{C.O.P.} &= \frac{T_4\left(\frac{T_1}{T_4} - 1\right)}{T_3\left(\frac{T_2}{T_3} - 1\right) - T_4\left(\frac{T_1}{T_4} - 1\right)} \quad (i) \end{aligned}$$

For isentropic compression process 1-2

$$\frac{T_2}{T_1} = \left(\frac{P_2}{P_1}\right)^{\frac{\gamma-1}{\gamma}} \quad (ii)$$

For isentropic expansion process 3-4

$$\frac{T_3}{T_4} = \left(\frac{P_3}{P_4}\right)^{\frac{\gamma-1}{\gamma}} \quad (iii)$$

Since, $P_2 = P_3$ and $P_1 = P_4$, therefore from equation (ii) and (iii)

Substitute equation (iv) in (i)

$$\begin{aligned} \text{C.O.P.} &= \frac{T_4}{T_3 - T_4} = \frac{1}{\frac{T_3}{T_4} - 1} \\ &= \frac{1}{\left(\frac{P_3}{P_4}\right)^{\frac{\gamma-1}{\gamma}} - 1} = \frac{1}{\left(\frac{P_2}{P_1}\right)^{\frac{\gamma-1}{\gamma}} - 1} \\ \text{C.O.P.} &= \frac{1}{(r_p)^{\frac{\gamma-1}{\gamma}} - 1} \\ r_p &= \text{Compression or Expansion ratio} = \frac{P_2}{P_1} = \frac{P_3}{P_4} \end{aligned}$$

Sub-refrigeration and air conditioning

Sem-5th sem Mechanical diploma

Refrigerating Compressor-

A refrigerating Compressor is a machine that compresses vapour refrigerant from the evaporator and to raise its pressure so that the corresponding saturation temperature is higher than that of the cooling medium.

Classification

1. According to the method of compression

- (a) Reciprocating compressors,
- (b) Rotary compressors, and
- (c) Centrifugal compressors.

2. According to the number of working strokes

- (a) Single acting compressors, and
- (b) Double acting compressors.

3. According to the number of stages

- (a) Single-stage (or single-cylinder) compressors, and
- (b) Multi-stage (or multi-cylinder) compressors.

4. According to the method of drive employed

- (a) Direct drive compressors, and
- (b) Belt drive compressors.

5. According to the location of the prime mover

- (a) Semi-hermetic compressors (direct drive, motor and compressor in separate housings), and
- (b) Hermetic compressors (direct drive, motor and compressor in same housings).

Important terms-

1. **Suction pressure.** It is the absolute pressure of refrigerant at the inlet of a compressor.
2. **Discharge pressure.** It is the absolute pressure of refrigerant at the outlet of a compressor.
3. **Compression ratio (or pressure ratio).** It is the ratio of absolute discharge pressure to the absolute suction pressure. Since the absolute discharge pressure is always more than the absolute suction pressure, therefore, the value of compression ratio is more than unity.

Note : The compression ratio may also be defined as the ratio of total cylinder volume to the clearance volume.

4. **Suction volume.** It is the volume of refrigerant sucked by the compressor during its suction stroke. It is usually denoted by v_s .

5. **Piston displacement volume or stroke volume or swept volume.** It is the volume swept by the piston when it moves from its top or inner dead position to bottom or outer dead centre position. Mathematically, piston displacement volume or stroke volume or swept volume,

$$v_p = \frac{\pi}{4} \times D^2 \times L$$

where

D = Diameter of cylinder, and

L = Length of piston stroke.

6. **Clearance factor.** It is the ratio of clearance volume (v_c) to the piston displacement volume (v_p). Mathematically, clearance factor,

$$C = \frac{v_c}{v_p}$$

7. **Compressor capacity.** It is the volume of the actual amount of refrigerant passing through the compressor in a unit time. It is equal to the suction volume (v_s). It is expressed in m^3/s .

8. **Volumetric efficiency.** It is the ratio of the compressor capacity or the suction volume (v_s) to the piston displacement volume (v_p). Mathematically, volumetric efficiency,

$$\eta_v = \frac{v_s}{v_p}$$

Reciprocating Compressor-

The compressors in which the vapour refrigerant is compressed by the reciprocating (*i.e.* back and forth) motion of the piston are called *reciprocating compressors*. These compressors are used for refrigerants which have comparatively low volume per kg and a large differential pressure, such as ammonia (R-717), R-12, R-22, and methyl chloride (R-40). The reciprocating compressors are available in sizes as small as 1/12 kW which are used in small domestic refrigerators and up to about 150 kW for large capacity installations.

The two types of reciprocating compressors in general use are single acting vertical compressors and double acting horizontal compressors. The single acting compressors usually have their cylinders arranged vertically, radially or in a V or W form. The double acting compressors usually have their cylinders arranged horizontally.

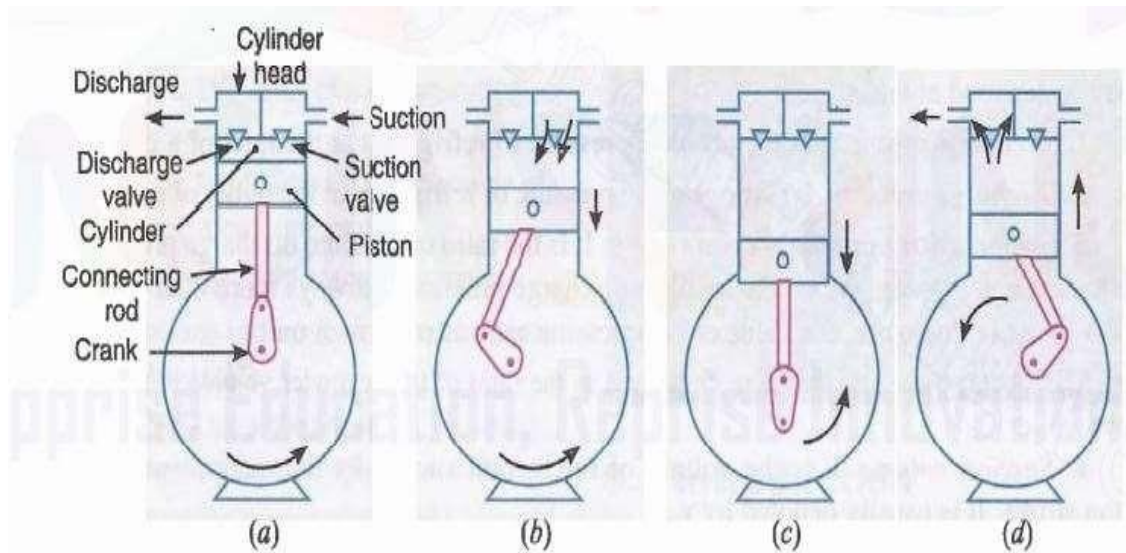

Fig. 9.1. Principle of operation of a single stage, single acting reciprocating compressor.

Working-

Let us Consider that the piston is at the top of its stroke as shown in (a).

It is called top dead centre of the piston.

In this position, the suction valve is held closed because of the pressure in the clearance space between the top of the piston and the cylinder head. The discharge valve is also closed because of the cylinder pressure acting on its top.

When the piston moves down, in suction stroke as in (b). The refrigerant left in the clearance space expands. Thus the volume of the cylinder increases and the pressure inside the cylinder decreases. When the pressure becomes slightly less than the suction pressure, the suction valve opens and the vapour refrigerant flows inside the cylinder. The flow continues until the piston reaches the bottom of the stroke. At the bottom of stroke as in (c), the suction stroke is closed because of the spring action. When the piston moves upward during compression stroke as in (d), the pressure inside the cylinder becomes greater than that on the top of the discharge valve, hence the discharge valve opens and the vapour refrigerant is discharged to condenser and the cycle is repeated.

Refrigeration and air conditioning notes

Refrigeration is defined as the process of achieving and maintaining a temperature below that of the surroundings. The aim is to cool some product or space to the required temperature.

Air Conditioning refers to the treatment of air and to simultaneously control its temperature, moisture content, cleanliness, odour and circulation, as required by occupants, a process, or products in the space.

Difference between a Refrigerator, Heat Pump, and Heat Engine

A heat engine is a system that converts Thermal energy into Mechanical Energy.

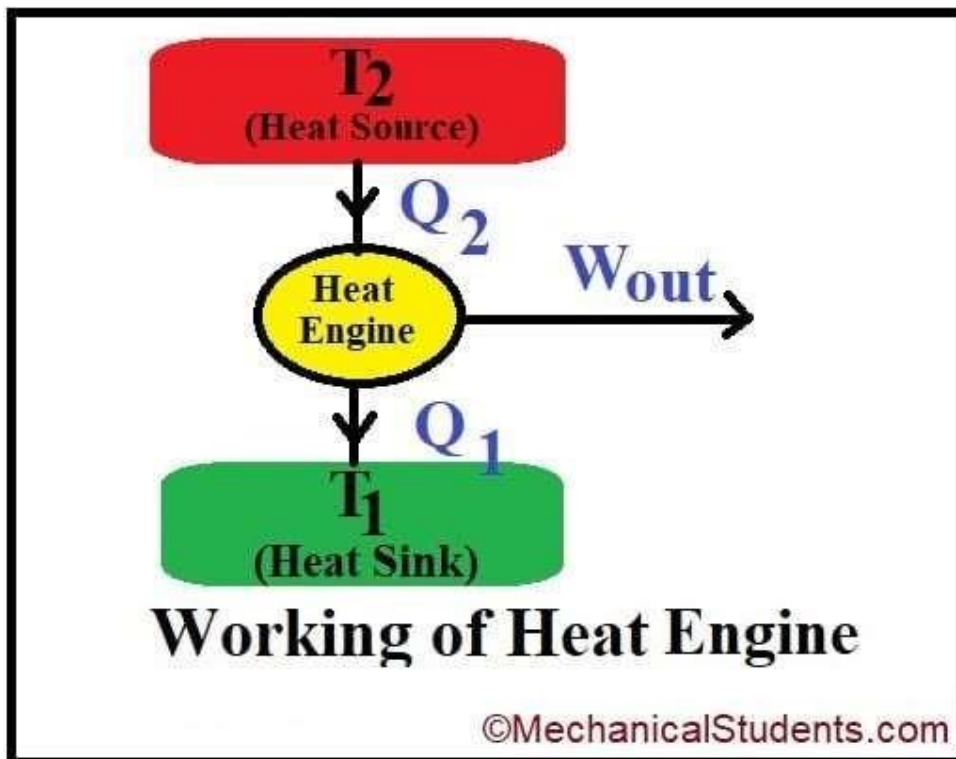

In a heat engine, the heat supplied to the engine is converted into useful work. If Q_2 is the heat supplied to the engine and Q_1 is the heat rejected from the heat engine, then the **network done** by the engine is given by

$$W_e = Q_2 - Q_1$$

So the performance of the engine or Efficiency is given by

Generally, **Efficiency** is calculated as = W_e/Q

A refrigerator is a reversed heat engine, where heat is pumped from low temperature (cold body--> Q_1) to high temperature (hot body--> Q_2)

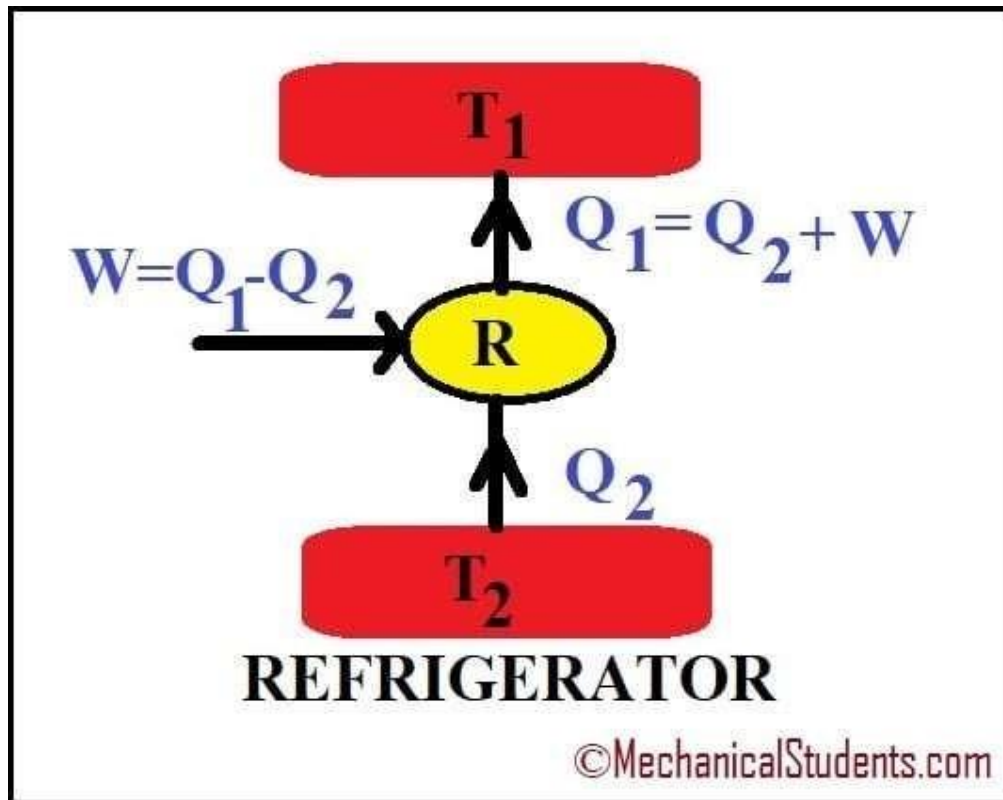

So, Work W_R is required to be done on the system.

$$W_R = Q_2 - Q_1$$

The performance of a refrigerator is the "ratio of the amount of heat taken from the Cold body Q_1 to the amount of work to be done on the system W_R ."

Any refrigerating system is a heat pump, which extracts heat from a cold body and delivers it to a hot body.

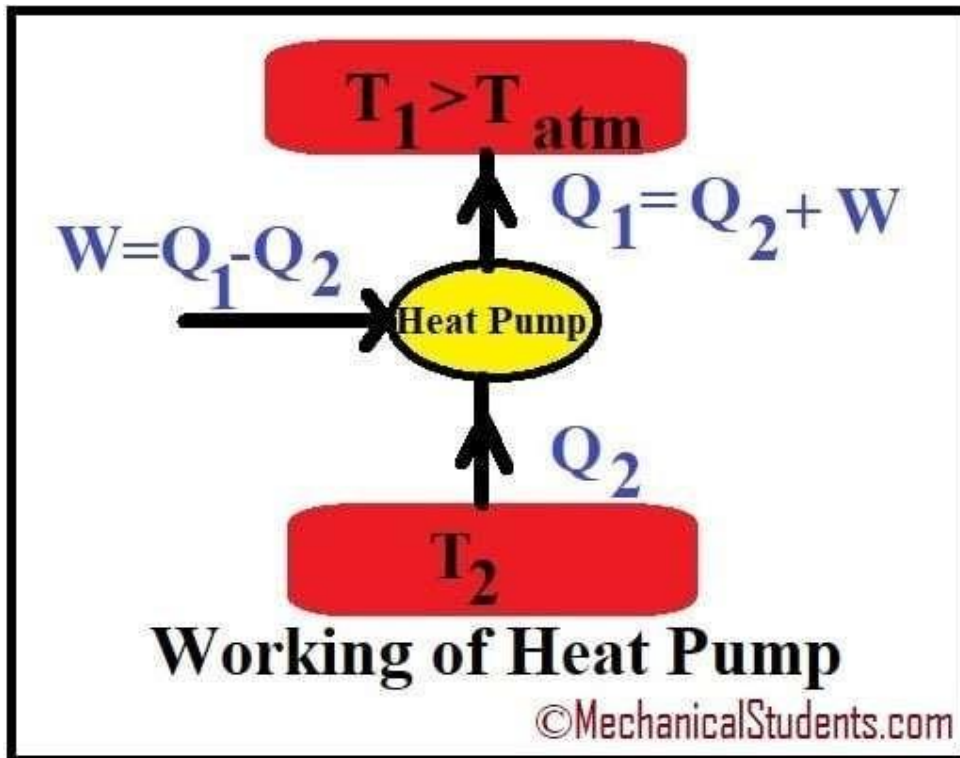

Thus there is no difference in the operation cycle of a refrigerator and a heat pump.

- The main difference between them is in their operating temperatures.
- A refrigerator works between cold body temperature (T_1) and atmospheric temp (T_a) whereas the heat pump operates between hot body temp (T_2) and the atmospheric temperature (T_a).
- A refrigerator used for cooling in summer can be used as a heat pump for heating in the winter season.
- so $W_p = Q_2 - Q_1$

Performance of refrigerator and heat pump

COP(Coefficient of performance)

COP is defined as the relationship between the power (kW) that is drawn out of the heat pump as cooling or heat, and the power (kW) that is supplied to the compressor.

the C.O.P is the reciprocal of efficiency and is given as

$$(C.O.P)_R = Q_1 / W_R = Q_1 / (Q_2 - Q_1) \text{----- for refrigerator}$$

$$(C.O.P)_{hp} = Q_2 / W_R = Q_2 / (Q_2 - Q_1) \text{----- for heat pump}$$

Refrigerator	Heat Pump	Heat Engine
A refrigerator is a reversed heat engine, where heat is pumped from a body at low temperature to a body at high temperature.	Any refrigerating system is a heat pump, which extracts heat from a cold body and delivers it to a hot body.	A heat engine is a system which converts Thermal energy into Mechanical Energy.
The network done by the refrigerator is given by $W_R = Q_2 - Q_1$	The network done by the heat pump is given by $W_p = Q_2 - Q_1$	The network done by the engine is given $W_e = Q_2 - Q_1$
The C.O.P. of Refrigerator is $(C.O.P)_R = \frac{Q_1}{W_R} = \frac{Q_1}{Q_2 - Q_1}$	The C.O.P. of heat pump is $(C.O.P)_{hp} = \frac{Q_2}{W_p} = \frac{Q_2}{Q_2 - Q_1}$	The C.O.P. of heat engine is $(C.O.P)_e = \frac{Q_2 - Q_1}{Q_2}$

Unit of refrigeration

Rating for Refrigeration indicates the rate of removal heat. The unit of refrigeration is expressed in terms of ton of refrigeration (TR). One ton of refrigeration is defined as the amount of refrigeration effect (heat transfer rate) produced during uniform melting of one ton (1000kg) of ice at 0°C to the water at the 0°C in 24 hours.

Calculation for one ton of refrigeration

Latent heat of ice is 335KJ/kg (heat absorbed during melting of one kg ice)

1 Ton of refrigeration, 1TR= 1000*335 in 24 hours

$$= \frac{1000 \times 335}{24 \times 60} \text{ in one minute}$$

$$= 232.6 \text{ kJ/min}$$

Theoretically one Ton of refrigeration taken as 232.6kJ/min, in actual practice, it is taken as 210kJ/min.

1 ton of refrigeration approximately equal to 3.5kW.

Lecture note

Sub-Refrigeration and air conditioning

Sem-5th sem Mechanical

Centrifugal Compressor

Centrifugal compressors; also known as turbo-compressors belong to the roto-dynamic type of compressors. In these compressors the required pressure rise takes place due to the continuous conversion of angular momentum imparted to the refrigerant vapour by a high-speed impeller into static pressure.

Working of Centrifugal Compressor

The Figure shows the working principle of a centrifugal compressor. As shown in the figure, low-pressure refrigerant enters the compressor through the eye of the impeller (1). The impeller (2) consists of a number of blades, which form flow passages (3) for refrigerant. From the eye, the refrigerant enters the flow passages formed by the impeller blades, which rotate at very high speed. As the refrigerant flows through the blade passages towards the tip of the impeller, it gains momentum and its static pressure also increases. From the tip of the impeller, the refrigerant flows into a stationary diffuser (4). In the diffuser, the refrigerant is decelerated and as a result the dynamic pressure drop is converted into static pressure rise, thus increasing the static pressure further. The vapour from the diffuser enters the volute casing (5) where further conversion of velocity into static pressure takes place due to the divergent shape of the volute. Finally, the pressurized refrigerant leaves the compressor from the volute casing (6). The gain in momentum is due to the transfer of momentum from the highspeed impeller blades to the refrigerant confined between the blade passages. The increase in static pressure is due to the self-compression caused by the centrifugal action. This is analogous to the gravitational effect, which causes the fluid at a higher level to press the fluid below it due to gravity (or its weight). The static pressure produced in the impeller is equal to the static head, which would be produced by an equivalent gravitational column. If we assume the impeller blades to be radial and the inlet diameter of the impeller to be small, then the static head, h developed in the impeller passage for a single stage is given by:

$$H = v^2/g$$

where h = static head developed, m

V = peripheral velocity of the impeller wheel or tip speed, m/s

g = acceleration due to gravity, m/s²

Hence increase in total pressure, ΔP as the refrigerant flows through the passage is given by:

$$\Delta P = \rho gh = \rho V^2$$

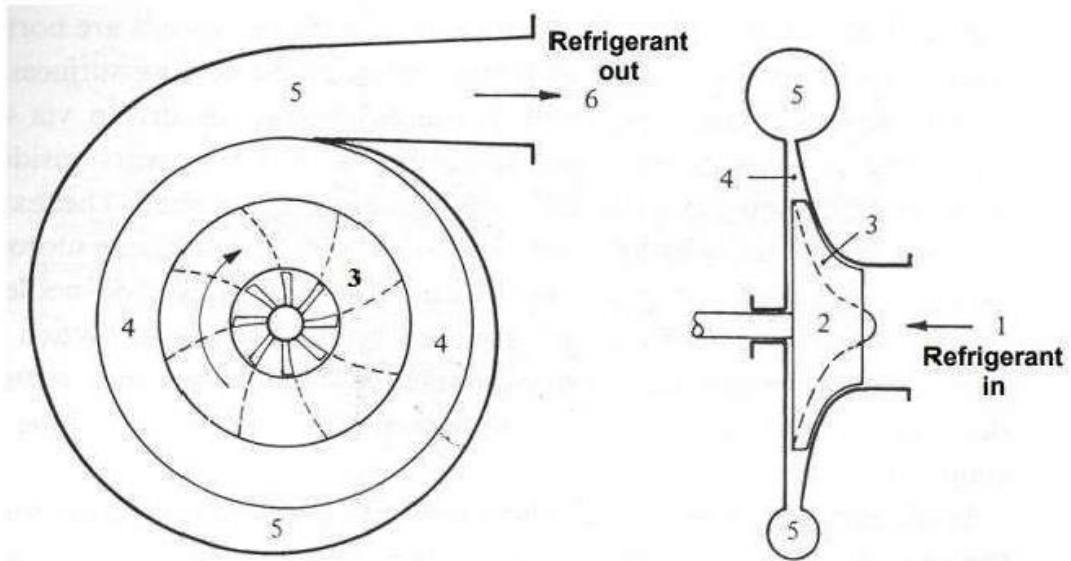

Centrifugal Compressor

1: Refrigerant inlet (eye); 2: Impeller; 3: Refrigerant passages
 4: Vaneless diffuser; 5: Volute casing; 6: Refrigerant discharge

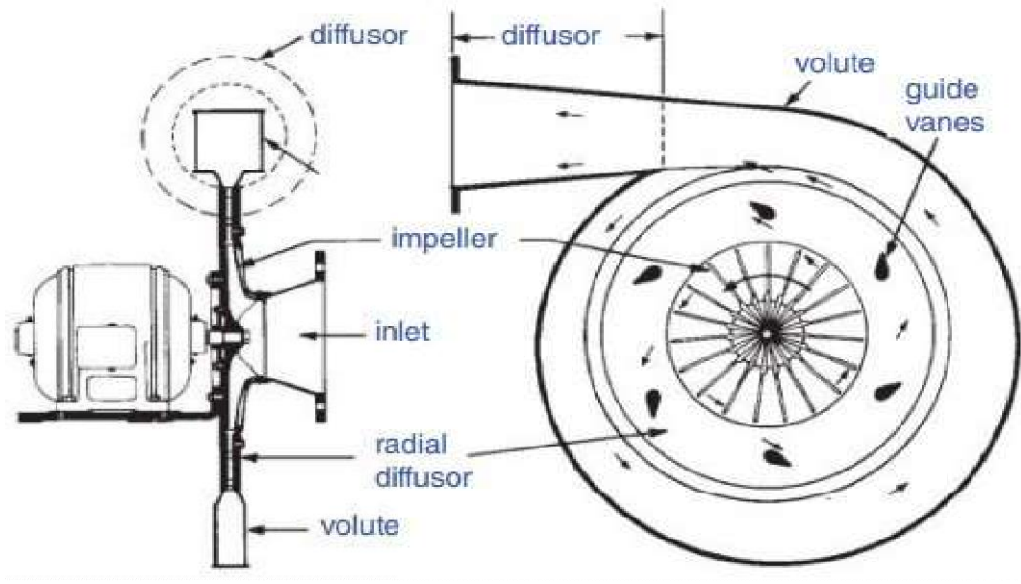

Lecture note

Sub-Refrigeration and air conditioning

Sem-5th sem Mechanical

Hermetically and Semi-hermetically sealed compressor

In hermetic compressors, the motor and the compressor are enclosed in the same housing to prevent refrigerant leakage. The housing has welded connections for refrigerant inlet and outlet and for power input socket. As a result of this, there is virtually no possibility of refrigerant leakage from the compressor. All motors reject a part of the power supplied to it due to eddy currents and friction, that is, inefficiencies. Similarly the compressor also gets heated-up due to friction and also due to temperature rise of the vapor during compression. In Open type, both the compressor and the motor normally reject heat to the surrounding air for efficient operation. In hermetic compressors heat cannot be rejected to the surrounding air since both are enclosed in a shell. Hence, the cold suction gas is made to flow over the motor and the compressor before entering the compressor. This keeps the motor cool. The motor winding is in direct contact with the refrigerant hence only those refrigerants, which have high dielectric strength, can be used in hermetic compressors. The cooling rate depends upon the flow rate of the refrigerant, its temperature and the thermal properties of the refrigerant. If flow rate is not sufficient and/or if the temperature is not low enough the insulation on the winding of the motor can burn out and short-circuiting may occur. Hence, hermetically sealed compressors give satisfactory and safe performance over a very narrow range of design temperature and should not be used for off-design conditions.

In some (usually larger) hermetic units, the cylinder head is removable so that the valves and the piston can be serviced. This type of unit is called a semi-hermetic (or semi-sealed) compressor.

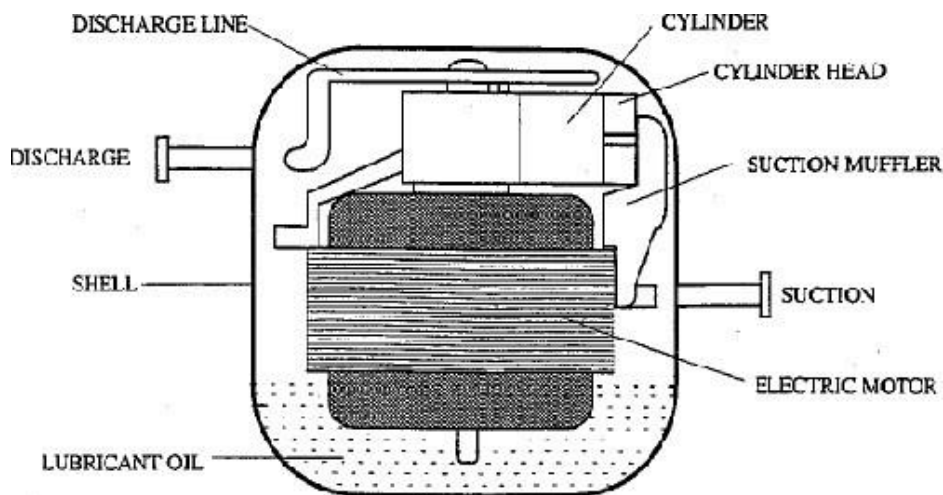



Hermetically sealed compressor



Semi-hermetically sealed compressor

Advantages and disadvantages of hermetic seal compressor

Advantages

- Leak proof / completely sealed housing - There is no route for gas to leak out this system. There are no shaft seals since both compressor and motor sealed in the same casing.
- Portable compressor and motor act as a single unit.
- No belt pulley coupling arrangement - No need disassembles the compressor from the motor to move the system from one place to another.
- Since there is no belt coupling or crankshaft, cost involved with the maintenance is less.
- It is compact; they require small space.
- Lubrication is simple; there is no external lubrication is required.
- It is less noisy

- Installation of hermetic sealed compressor is very easy.

Disadvantages

- They are not intended to repairing since the moving parts are inaccessible if there is any problem you need to do you replace the whole unit.
- Burnout winding can contaminate entire system.
- Only electric power sources can run this unit.

Expansion Valve - It is one of the component of VCRS as well as VARS.

Expansion Valve is used after condenser. It brings down the pressure of refrigerant to the evaporator pressure.

There are mainly three types of Expansion devices.

They are.

(i) Capillary tube - (ii) Automatic Expansion valve.

(iii) Thermal Expansion Valve.

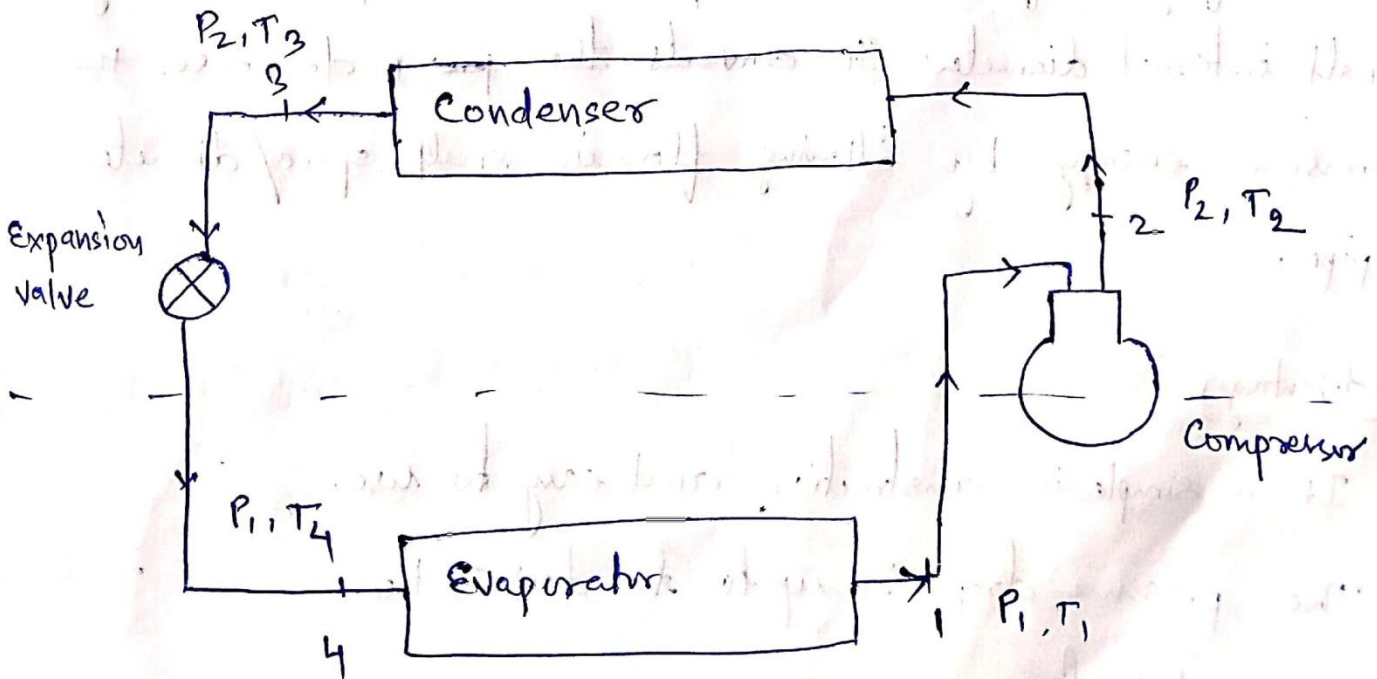

1-2 - Compressor

3-4 - Expansion device

2-3 - Condenser

4-1 - Evaporator

Capillary tube - It is the simplest type of expansion device.

It is of length 6 meter length having 0.5 to 2.5 mm internal diameter.

It is generally made up of metals like copper.

It is used in domestic refrigerators, freezers, air-conditioners.

Working of Capillary tube It has mainly two components.

(i) Metallic cap/entry.

(ii) Tube part.

The Metallic cap assume ~~as~~ entry and exit of refrigerant.

- The metallic cap/entry takes liquid refrigerant at higher pressure from Condenser and releases it to the other end, bringing down the

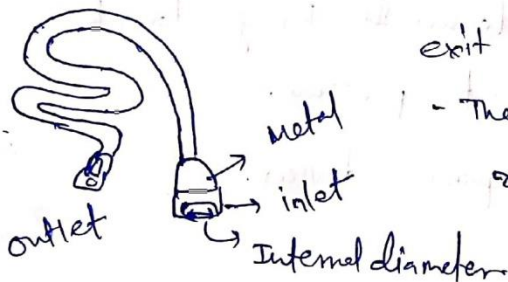

pressure as well as temperature.

- The refrigerant flows in tube part. The tube part has very small internal diameter. It converts the ~~the~~ ~~p~~ decreases the pressure energy by allowing flow in small space/diameter pipe.

Advantages

- (i) It is simple in construction and easy to use.
- (ii) The pressure drop is up to the design value.
- (iii) The cost is less.

Disadvantages

- (i) ~~The~~ It is not possible to control the flow of refrigerant in the tube.
- (ii) The ~~out~~ exit pressure and temperature may be above or below the desired value.

Designation of Refrigerants

Refrigerants are designated by letter R followed by certain numbers.

Refrigerant followed by 2-digit number = Methane derived

Refrigerant followed by 3-digit number = Ethane derived

Chemical formula of Refrigerant



$$n+p+q = 2m+2$$

Ex - $R-12 = R-012$

$$m-1 = 0 \Rightarrow m=1$$

$$n+1 = 1 \Rightarrow n=0$$

$$q = 2$$

Also,

$$n+p+q = 2m+2$$

$$\Rightarrow p+q = 4-2$$

$$= 2$$

So, $R-12 = CH_0 Cl_2 F_2$

$$= CCl_2 F_2 \text{ (Dichloro Difluoromethane)}$$

For practice R-114 = $C_2Cl_2F_4$

$$m-1=1 \Rightarrow m=2$$

$$n+p+q = 2m+2$$

$$n+1=1 \Rightarrow n=0$$

$$\Rightarrow p = 6 - 4 = 2$$

$$q = 4$$

Fully Halogenated Refrigerant = Chlorofluoro Carbon Refrigerants

e.g. - R-11, R-12, R-13

Halogens with hydrogen Refrigerants = Hydrogen chlorofluoro carbon refrigerants.

e.g. - R-134, R152a

Inorganic Refrigerants

R-700 + Molecular Mass

e.g. - NH_3 Mass = 17 \Rightarrow R-717

Unsaturated Refrigerants - 4 digits.

$$R-1(m-1)(n+1)q$$

and $n+p+q = 2m$

e.g. - R-1150 $m-1=1 \Rightarrow m=2$ $n+1=1 \Rightarrow n=0$

$$q=0, \quad n+p+q=2m \Rightarrow 0+p+0=4$$

$p=4$

So, R-1150 = C_2Cl_4 (Tetrachloroethane)

- **Thermodynamics Properties**

- Critical temperature should be high.
- Specific heat of refrigerant in *liquid* phase must be *low* and in *vapour* phase must be *high*.
- Enthalpy of vaporization should be high.
- Thermal heat conductivity should be high.
- Freezing point should be low.
- Specific volume of refrigerant at the inlet of compressor should be low.
- Temperature of refrigerant at the outlet of compressor should be low.

- **Chemical Properties**

- It should not be toxic and non flammable.
- Refrigerant should not be miscible with oil or *completely* immiscible with oil.
- It should not attack material of construction of equipment.

- **Physical Properties**

- Its viscosity should be low.
- There is no leakage tendency.

By Pass Factor (Heating Coil)

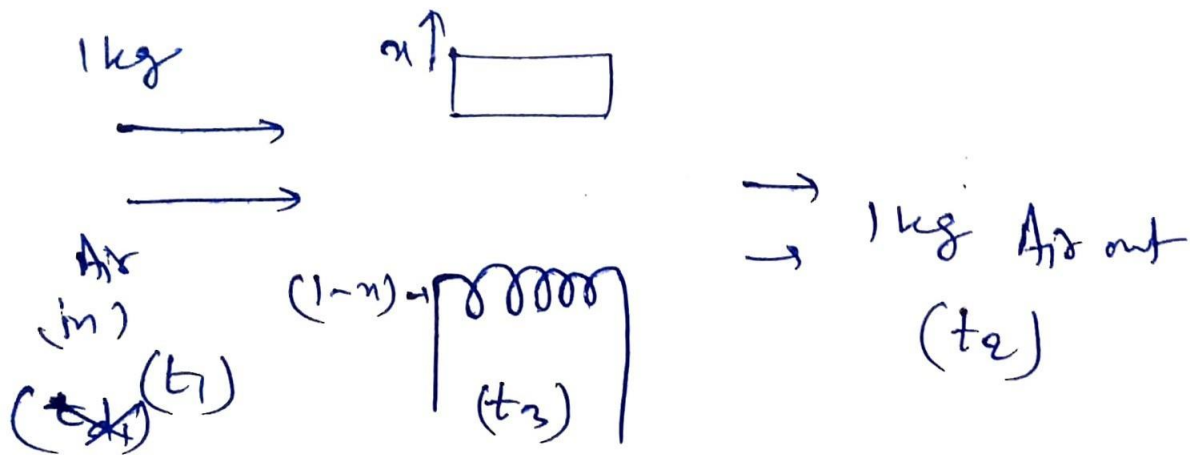

• Energy Balance,

$$\alpha c_{pm} t_1 + (1-\alpha) c_{pm} t_3 = 1 \times c_{pm} t_2$$

$$\Rightarrow \alpha c_{pm} t_1 - \alpha c_{pm} t_3 = c_{pm} t_2 - c_{pm} t_3$$

$$\Rightarrow \alpha (t_1 - t_3) = (t_2 - t_3)$$

$$\Rightarrow \alpha = \frac{t_2 - t_3}{t_1 - t_3} = \frac{t_3 - t_2}{t_3 - t_1}$$

$$\alpha = \frac{\text{Actual change}}{\text{Maximum change}}$$

(BPF)

$$\eta = 1 - \text{BPF}$$

By Pass factor (cooling coil)

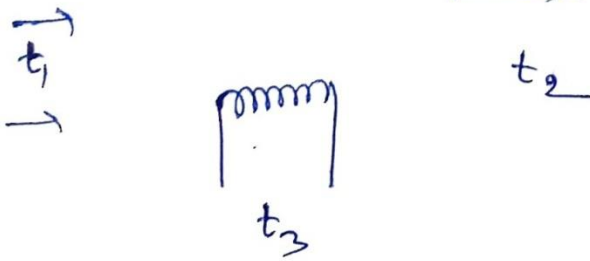

$$\text{BPF} = \frac{\text{Actual change}}{\text{Maximum change}} = \frac{t_2 - t_3}{t_1 - t_3}$$

Sensible Heat factor

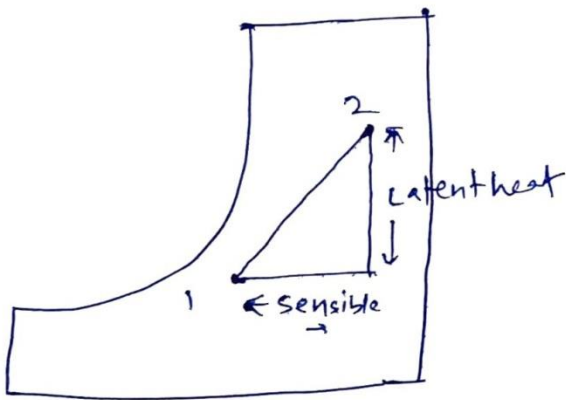

$$\begin{aligned} \text{Sensible Heat factor} &= \frac{\text{Sensible Heat}}{\text{Total Heat}} \\ &= \frac{\text{sensible heat}}{\text{Sensible heat} + \text{Latent Heat}} \end{aligned}$$

Questions

Q A cooling coil has inlet air temperature as 15°C and outlet as 12°C while the coil is maintained at 10°C . What is the efficiency of coil?

Q A Heating coil has inlet air & outlet air temp. as 20°C and 25°C while coil is maintained at 30°C . Obtain BPF & efficiency.

Summer Air Conditioning System

It is the most popular type of air conditioning system.

In this type of air conditioning system, the air is cooled and dehumidified.

The block diagram for this type of air conditioning system is given below

Block diagram

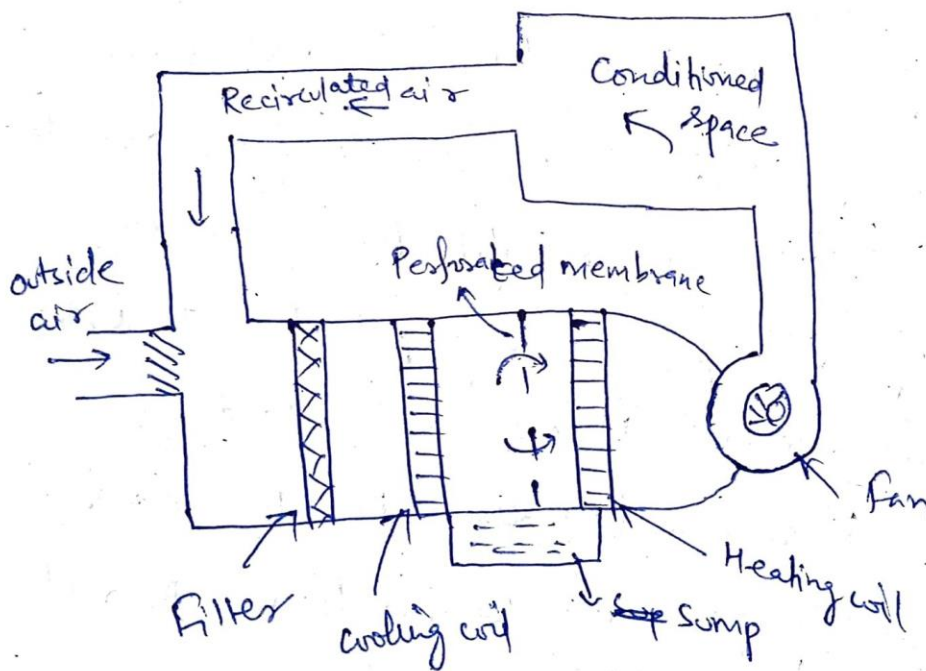

Components

- (i) Damper - It is the first component that interacts with the outside air. It directs the path of outside air to go through filter.

(ii) Filter - It is a device that is used to remove the dirt particle present in the air. It confirms air with no contamination.

(iii) Cooling coil - There is coil which is maintained at a temperature much below the dry bulb temperature. It is done to decrease the temperature of air. The temperature is decreased as per the BPF and efficiency of cooling coil.

(iv) Perforated membrane - It is a membrane which is responsible for decrease in humidity of air. The air after cooling from cooling coil passes through it, it loses its moisture and moisture is collected in sump.

(v) Heating Coil - Dehumidification from perforated membrane of air takes it to heating coil. It is done to attain a desirable Dry bulb temperature and relative humidity.

(vi) Fan - It is used to deliver the conditioned air to space or room.

Working - The outside air is taken inside. Damper directs the air formed by mixing outside air and recirculated air from conditioned space. The air is forwarded towards filter. Filter cleans the air from dirt particles. Cooling coil

decrease the temperature of air as per its efficiency. The moisture level is decreased by perforated membrane. Heating coil further takes it to desired dry bulb temperature. Finally, fan delivers the conditioned air to room. This is repeated for cycle of operation.

1. Air Conditioning Systems

Air Conditioning is the branch of engineering that deals with the study of conditioning of air i.e. supplying and maintaining desirable internal atmospheric conditions for human comfort, irrespective of external conditions.

Factors affecting Air Conditioning

- (i) Temperature of Air - The control of temperature within an enclosed space even when outside temperature can be above or below than the room temperature.
- (ii) Humidity of Air - It indicates addition of moisture or reduction of moisture with respect to season. It is done to have comfortable conditions.
- (iii) Purity of Air - The comfort of human body is greatly affected by contaminated air. So proper cleaning, filtration of air is necessary.
- (iv) Motion of Air - In order to keep constant temperature, proper circulation of air is necessary.

Air Conditioning system

The system that effectively controls ~~these~~ ^{the} conditions to produce the desired effects of occupants is known as Air conditioning systems.

Equipments used

- (i) Circulation fan - For movement of air in and out of room.
- (ii) Air conditioning unit - for humidification and dehumidification of air.
- (iii) Supply duct - For supply of conditioned air to room.
- (iv) Supply outlets -
- (v) Return outlets -
- (vi) Filter - For filtration of air.

Winter Air Conditioning System

Air conditioning system is divided into three types.

- (i) Winter Air conditioning
- (ii) Summer Air ~~or~~ conditioning
- (iii) Year-around air conditioning.

In winter air conditioning, the air is heated and it is accompanied by humidification.

Block diagram

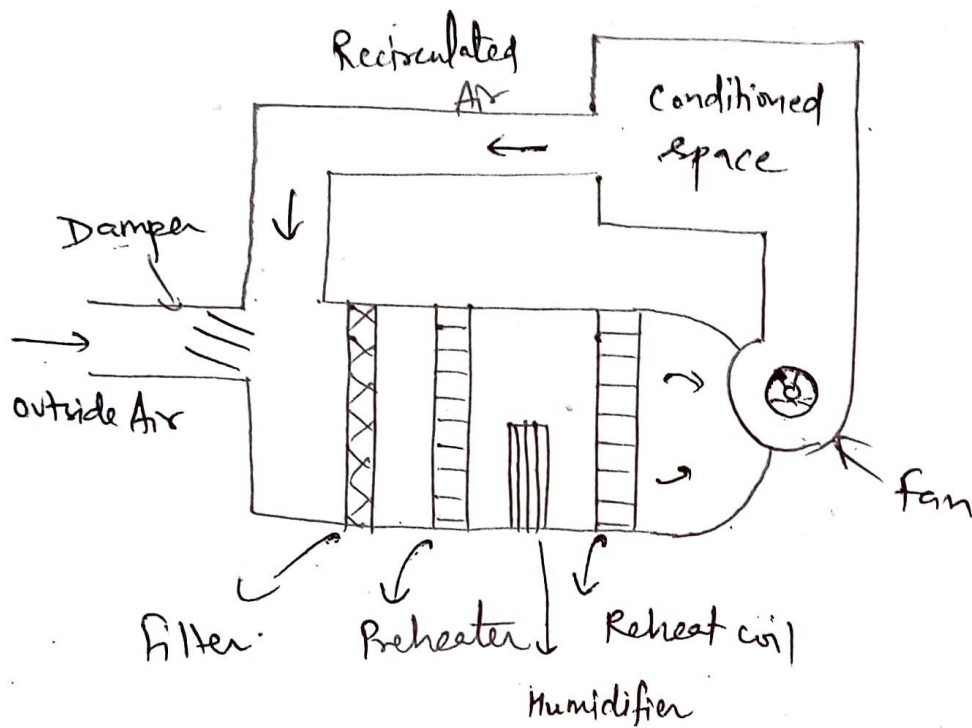

~~Ex~~ The components of window Air Conditioning system are

- (i) Dampener - It is path director. It is used to direct the outside air. It allows mixing of outside air and recirculated air.
- (ii) Filter - It is simply cleaning of mixed air made up of outside air and recirculated air.
- (iii) Preheater - It is used to heat the combined air. It is done just before humidification. The humidification process can decrease the temperature. So it is preheated to overcome the problem.

(iv) Humidifier - It is device that adds water vapour to air. The temperature of air can be decreased during this process.

(v) Reheat coil - It is the coil that is used to again heat the air coming just after humidifier so that the desired temperature can be achieved.

(vi) Fan - This is the last component which directly supplies the conditioned air to desired room or space.

Working - The outside air is taken inside the chamber.

It is directed by damper. Damper allows mixing of recirculated air and outside air. Thereafter, filtration of air occurs.

The preheating of air is done using preheater. The temperature is now somehow increased. Water vapour are added after

preheater. It brings down temperature. Reheater adds heat to air and finally fan supplies the air to room. The rest air of room is again recirculated for further process.